

Application

Globe valves (V46) are industrial valves designed to open or close the service fluid flow fully. Control (V40) valves are used to regulate flowing fluid. Both types are used especially in power engineering, chemical industry as well as other industries putting great demands on functionality at high pressures and high temperatures.

Working medium

- water
- steam
- gas
- other fluids
- seawater

Technical description

The valve has a one-piece body which can be a forged or a cast depending on nominal size and nominal pressure. The yoke-type bonnet is also cast or forged and is connected with the body by means of a bolted or flanged joint. The seat and the disc are hard faced. The disc is made as either a plug type disc (valves V46) or a regulating disc (valves V40). Valves with regulating disc have a linear regulating characteristic. Tightness is achieved by means of special graphite gaskets and packing rings. Tightness of the stem of valve type V46.6 is achieved by a bellow. The valves are designed so as to be earthquake resistant.

Operation

- manual (hand wheel, chain wheel)
- electric actuator
- pneumatic actuator, hydraulic actuator
- actuator located out of the valve

Globe valves can be equipped with a locking device. Position indicator on request.

Operation is dimensioned for the working parameters acc. to EN 13709.



Testing

Valves are subject to shell strength test, shell tightness test, seat tightness test and functionality test according to EN 12266 with water as a standard. If required, other tests may be performed as well.

Connection to the piping

- flanged ends acc. to EN 1092-1, ISO 7005-1, GOST 12815-80
- welded ends acc. to EN 12627

Installation

Valves may be installed in any position. The flow direction shall correspond to the arrow on the valve body.

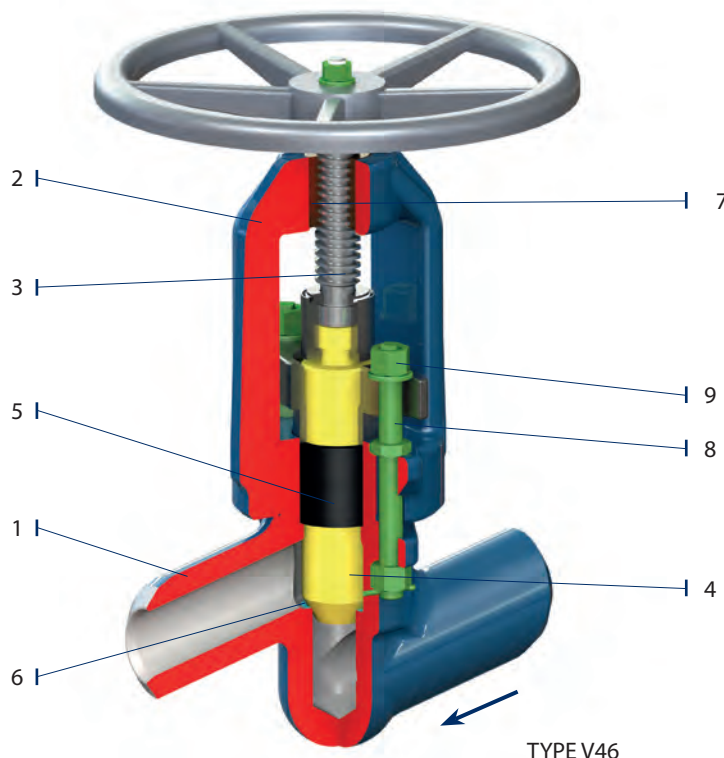

Position	Component
1	Body
2	Bonnet
3	Top stem
4	Bottom stem
5	Packing
6	Seat
7	Stem nut
8	Bolts
9	Nuts



PN 63-100 • DN 10-200 • Tmax 550 °C (450 °C)

Connection: EN 1092-1, ISO 7005-1, GOST 12815-80 FLANGED ENDS
 EN 12627 WELDED ENDS

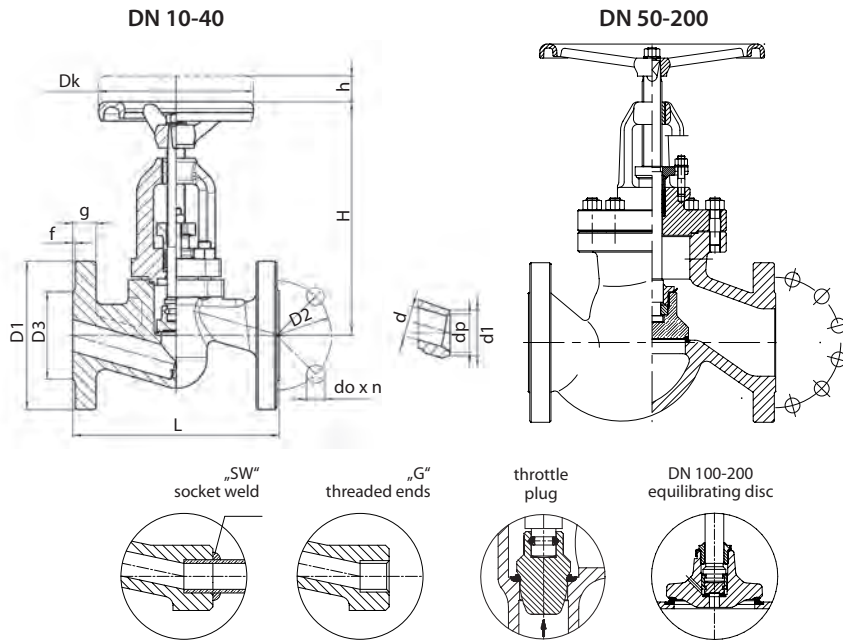

Material

Component	Tmax 450 °C	Tmax 530 °C	Tmax 560 °C	Tmax 550 °C **	Tmax 550 °C **
Body, bonnet DN 15-40	P250GH (1.0460)	16Mo3 (1.5415)	13CrMo4-5 (1.7335)	X6CrNiTi18-10 (1.4541)	X2CrNiMo17-12-2 (1.4404)
Body, bonnet DN 50-200	GP240GH (1.0619)	G20Mo5 (1.5419)	G17CrMo5-5 (1.7357)	CX5CrNi19-10 (1.4308)	GX5CrNiMo19-11-2 (1.4408)
Seat	13Cr	Stellite	Stellite	SS316, Stellite	SS316, Stellite
Disc DN 15-50	13Cr	16Mo3 (1.5415)	13CrMo4-5 (1.7335)	1.4541	1.4404
Disc DN 65-200	P250GH (1.0460)	16Mo3 (1.5415)	13CrMo4-5 (1.7335)	1.4541	1.4404
Disc ring	13Cr	Stellite	Stellite	SS316, Stellite	SS316, Stellite
Stem	13Cr	13Cr	13Cr	1.4541	1.4404
Gasket	Graphite + Austenite				

** The temperatures listed above are designed for non-aggressive media. For aggressive media apply Tmax 250 °C.

PN	DN	d	Flanged ends										Welded ends				
			D1		D3		D2	do x n	L	g	H	Dk	kg	*d1	*dp	L	kg
			GOST	EN	GOST	EN											
63 100	10	10	100		42	40	70	14 x 4	210	20	160	120	5,4	18	13	150	3
	15	14	105		47	45	75	14 x 4	210	20	160	120	5,4	22	17	150	3
	20	19	125	130	58		90	18 x 4	230	22	160	120	9,8	28	22	160	3
	25	23	135	140	68		100	18 x 4	230	24	160	120	10,8	35	28,5	160	3
	32	30	150	155	78		110	22 x 4	260	24	210	160	15	44	36,5	230	9,3
	40	38	165	170	88		125	22 x 4	260	28	210	160	15,7	50	43	230	9,5
63	50	45	175	180	102		135	22 x 4	300	26	250	200	30,7	62	54	300	19,9
	65	62	200	205	122		160	22 x 8	340	26	290	250	46	77	69	340	30,9
	80	73	210	215	133	138	170	22 x 8	380	28	300	320	62	91	81	380	48,7
	100	94	250		158	162	200	22 x 8	430	30	500	360	121,5	117	104	430	95,1
	125	120	295		184	188	240	26 x 8	500	34	600	400	168	144	130,5	500	137,9
	150	144	340	345	212	218	280	33 x 8	550	36	700	500	251	172	156,5	550	201,1
100	200	195	405	415	285		345	36 x 12	650	42	900	600	290	223	204,5	650	215
	50	45	195		102		145	26 x 4	300	28	250	200	30,7	62	54	300	19,9
	65	62	220		122		170	26 x 8	340	30	290	280	46	77	69	340	30,9
	80	73	230		133	138	180	26 x 8	380	32	300	360	62	91	81	380	48,7
	100	94	265		158	162	210	30 x 8	430	36	500	360	121,5	117	104	430	95,1
	125	120	310	315	184	188	250	33 x 8	500	40	600	400	168	144	127	500	137,9
150	144	350	355	212	218	290	33 x 12	550	44	700	500	251	172	154	550	201,1	
200	195	430		285		360	36 x 12	650	52	900	600	295	223	199,5	650	218	

* These dimensions of welded ends may vary acc. to the specifications of customer orders.

PN 160 • DN 10-200 • Tmax 560 °C (450 °C)

Connection: EN 1092-1, ISO 7005-1, GOST 12815-80 FLANGED ENDS
 EN 12627 WELDED ENDS

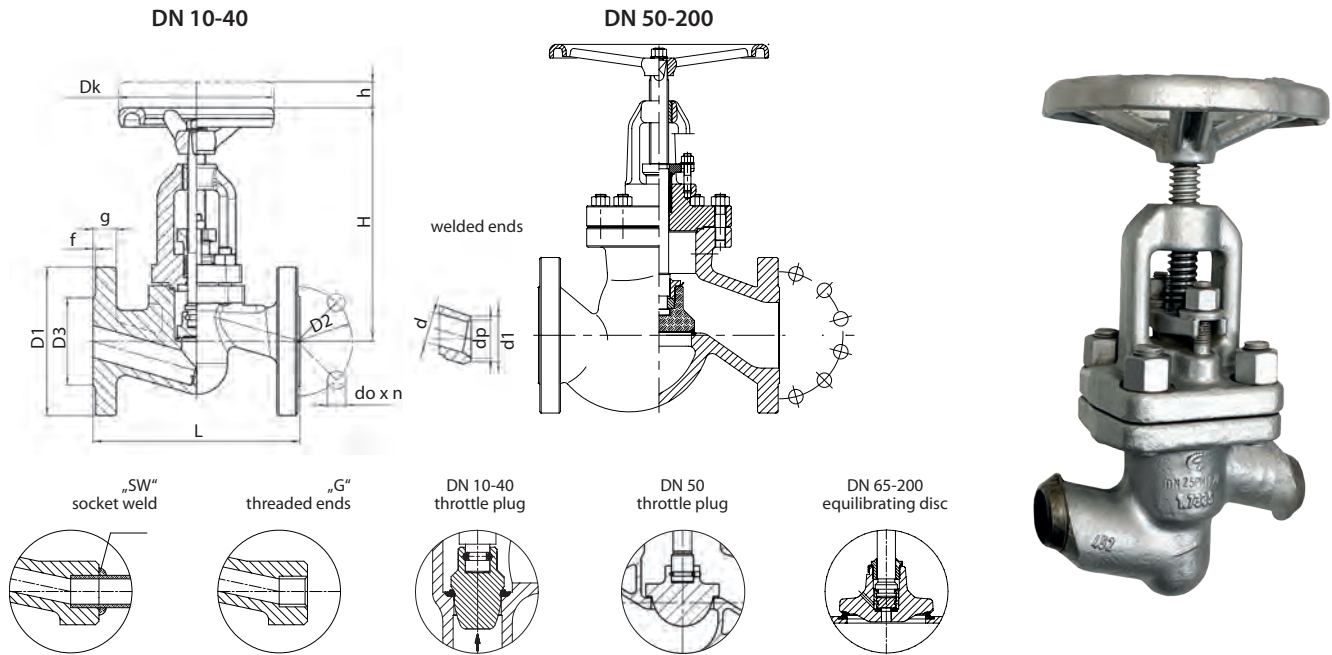

Material

Component	Tmax 450 °C	Tmax 530 °C	Tmax 560 °C	Tmax 550 °C**	Tmax 550 °C**
Body, bonnet DN 15-40	P250GH (1.0460)	16Mo3 (1.5415)	13CrMo4-5 (1.7335)	X6CrNiTi18-10 (1.4541)	X2CrNiMo17-12-2 (1.4404)
Body, bonnet DN 50-200	GP240GH (1.0619)	G20Mo5 (1.5419)	G17CrMo5-5 (1.7357)	CX5CrNi19-10 (1.4308)	GX5CrNiMo19-11-2 (1.4408)
Seat	13Cr	Stellite	Stellite	SS316, Stellite	SS316, Stellite
Disc DN 15-50	X30Cr13 (1.4028)	X30Cr13 (1.4028)	13CrMo4-5 (1.7335)	1.4541	1.4404
Disc DN 65-200	P250GH (1.0460)	16Mo3 (1.5415)	13CrMo4-5 (1.7335)	1.4541	1.4404
Disc ring	13Cr	Stellite	Stellite	SS316, Stellite	SS316, Stellite
Stem	X20Cr13 (1.4021)	X17CrNi16-2 (1.4057)	X39CrMo17-1 (1.4122)	1.4541	1.4404
Gasket	Graphite + Austenite				

** The temperatures listed above are designed for non-aggressive media. For aggressive media apply Tmax 250 °C.

PN 160

DN	d	Flanged ends												Welded ends				
		D1		D3		D2	do x n	L	g	f	H	h	Dk	kg	*d1	*dp	L	kg
		GOST	EN	GOST	EN													
10	10	-	100	-	40	70	14 x 4	210	20	2	175	13	120	5,4	18	13	150	3,2
15	15	105		47	45	75	14 x 4	210	20	2	175	13	120	5,4	22	17	150	3
20	20	125	130	58		90	18 x 4	230	22	2	215	13	120	9,7	28	21	160	3
25	24	135	140	68		100	18 x 4	230	24	2	215	13	120	10,6	35	27	160	2,8
32	30	150	155	78		110	22 x 4	260	24	2	245	16	160	15,6	44	34,5	230	10,1
40	38	165	170	88		125	22 x 4	260	28	3	245	18	160	17,3	50	41	230	9,4
50	47	195		102		145	30 x 4	300	30	3	300	22	180	29	62	52,5	300	8,7
65	63	220		122		170	26 x 8	340	34	3	330	30	280	47,8	77	65	340	16
80	73	230		133	138	180	26 x 8	380	36	3	375	40	360	62	91	76,5	380	23
100	95	265		158	162	210	30 x 8	430	40	3	520	55	360	112	117	98,5	430	55
125	120	310	315	184	188	250	33 x 8	500	44	3	600	65	400	165	144	120,5	500	70
150	145	350	355	212	218	290	33 x 12	550	44	3	700	70	500	251	172	144,5	550	174
200	190	430		285		360	36 x 12	650	60	3	900	110	600	295	223	189	650	220

* These dimensions of welded ends may vary acc. to the specifications of customer orders.



PN 250-400 • DN 10-125 • Tmax 650 °C (450 °C)

Connection: EN 1092-1, ISO 7005-1 FLANGED ENDS
 EN 12627 WELDED ENDS

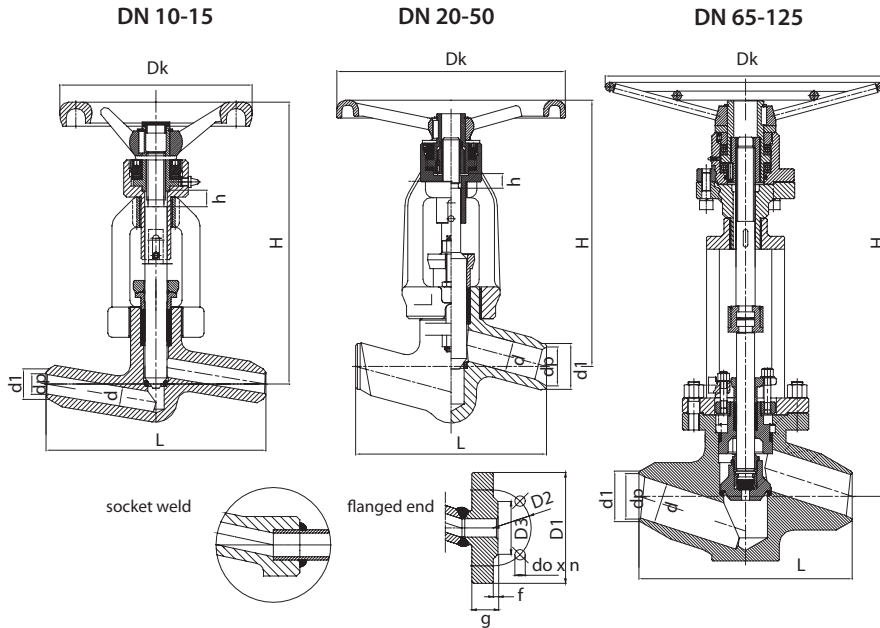

Material

Component	Tmax 450 °C	Tmax 530 °C	Tmax 560 °C	Tmax 600 °C	Tmax 570 °C	Tmax 650 °C
Body	P250GH (1.0460)	16Mo3 (1.5415)	13CrMo4-5 (1.7335)	10CrMo9-10 (1.7380)	14MoV6-3 (1.7380)	X10CrMoVNB9-1 (1.4903)
Bonnet	DN15-25 13CrMo4-5 (1.7335) , DN32-100 G17CrMo5-5 (1.7357)					
Seat	VT9, Stellite, G18 8 Mn					
Disc DN 15-50	X39CrNi17-1 (1.4122) , X22CrMoV12-1 (1.4923)					X22CrMoV12-1 (1.4923)
Disc DN 65-125	P250GH (1.0460)	16Mo3 (1.5415)	13CrMo4-5 (1.7335)	1.4541	1.4404	X10CrMoVNB9-1 (1.4903)
Disc ring						G18 8 Mn
Stem	X17CrNi16-2 (1.4057) , X39CrNi17-1 (1.4122)					X17CrNi16-2 (1.4057)
Gasket	Graphite					

PN 250

DN	Welded ends				d	H	h	Dk	Flanged ends							
	*d1	*dp	L	kg					D1	D3	D2	do x n	L	g	f	kg
10	20	12	150	10	9	205	12	140	125	40	85	18 x 4	230	24	2	13,7
15	22	16	150	9	14	205	12	140	130	45	90	18 x 4	230	26	2	13,7
20	28	19,5	160	9	18	266	19	200	-	-	-	-	-	-	-	-
25	35	26,5	160	9	24	266	19	200	150	68	105	22 x 4	260	28	2	18,3
32	44	32,5	300	30	30	418	23	360	-	-	-	-	-	-	-	-
40	50	38,5	300	30	34	418	37	360	185	88	135	26 x 4	300	34	3	45,2
50	62	45	300	30	42	418	37	360	200	102	150	26 x 8	350	38	3	47
65	77	59,5	340	40	56	714	45	700	230	122	180	26 x 8	400	42	3	71,3
80	117	93	380	70	76	637	36	500	255	138	200	30 x 8	450	46	3	107,5
100	144	116,5	430	90	92	720	50	500	300	162	235	33 x 8	520	54	3	157,5
125	159	120,5	500	125	112	750	65	500	340	188	275	33 x 12	600	60	3	220,9

* These dimensions of welded ends may vary acc. to the specifications of customer orders.