

Application

Globe valves (V46) are industrial valves designed to open or close the service fluid flow fully. Control (V40) valves are used to regulate flowing fluid. Both types are used especially in power engineering, chemical industry as well as other industries putting great demands on functionality at high pressures and high temperatures.

Working medium

- water
- steam
- gas
- other fluids
- seawater

Technical description

The valve has a one-piece body which can be a forged or a cast depending on nominal size and nominal pressure. The yoke-type bonnet is also cast or forged and is connected with the body by means of a bolted or flanged joint. The seat and the disc are hard faced. The disc is made as either a plug type disc (valves V46) or a regulating disc (valves V40). Valves with regulating disc have a linear regulating characteristic. Tightness is achieved by means of special graphite gaskets and packing rings. Tightness of the stem of valve type V46.6 is achieved by a bellow. The valves are designed so as to be earthquake resistant.

Operation

- manual (hand wheel, chain wheel)
- electric actuator
- pneumatic actuator, hydraulic actuator
- actuator located out of the valve

Globe valves can be equipped with a locking device. Position indicator on request.

Operation is dimensioned for the working parameters acc. to EN 13709.



Testing

Valves are subject to shell strength test, shell tightness test, seat tightness test and functionality test according to EN 12266 with water as a standard. If required, other tests may be performed as well.

Connection to the piping

- flanged ends acc. to EN 1092-1, ISO 7005-1, GOST 12815-80
- welded ends acc. to EN 12627

Installation

Valves may be installed in any position. The flow direction shall correspond to the arrow on the valve body.

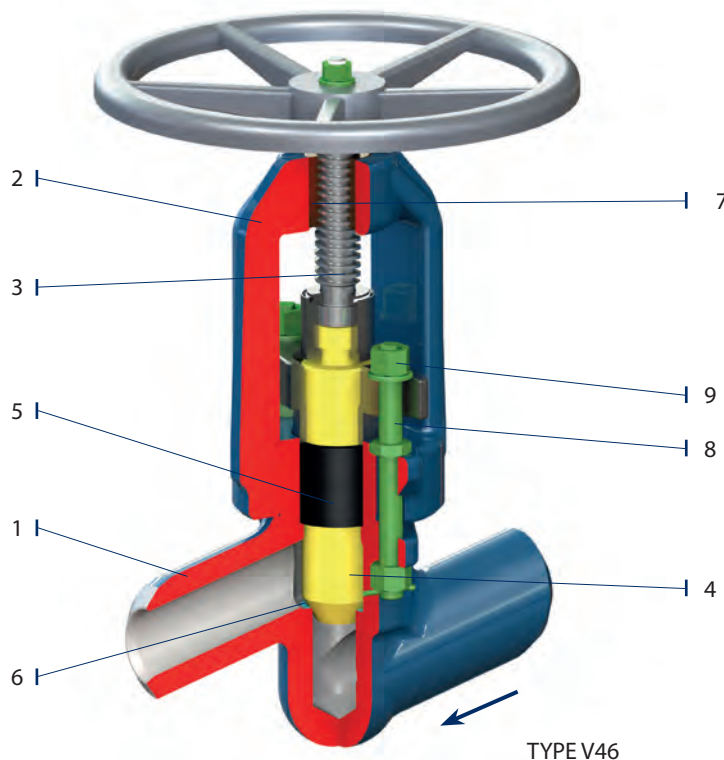

Position	Component
1	Body
2	Bonnet
3	Top stem
4	Bottom stem
5	Packing
6	Seat
7	Stem nut
8	Bolts
9	Nuts



PN 16-40 • DN 15-200 • Tmax 550°C (450°C)

Connection: EN 1092-1, ISO 7005-1, GOST 12815-80 FLANGED ENDS
 EN 12627 WELDED ENDS

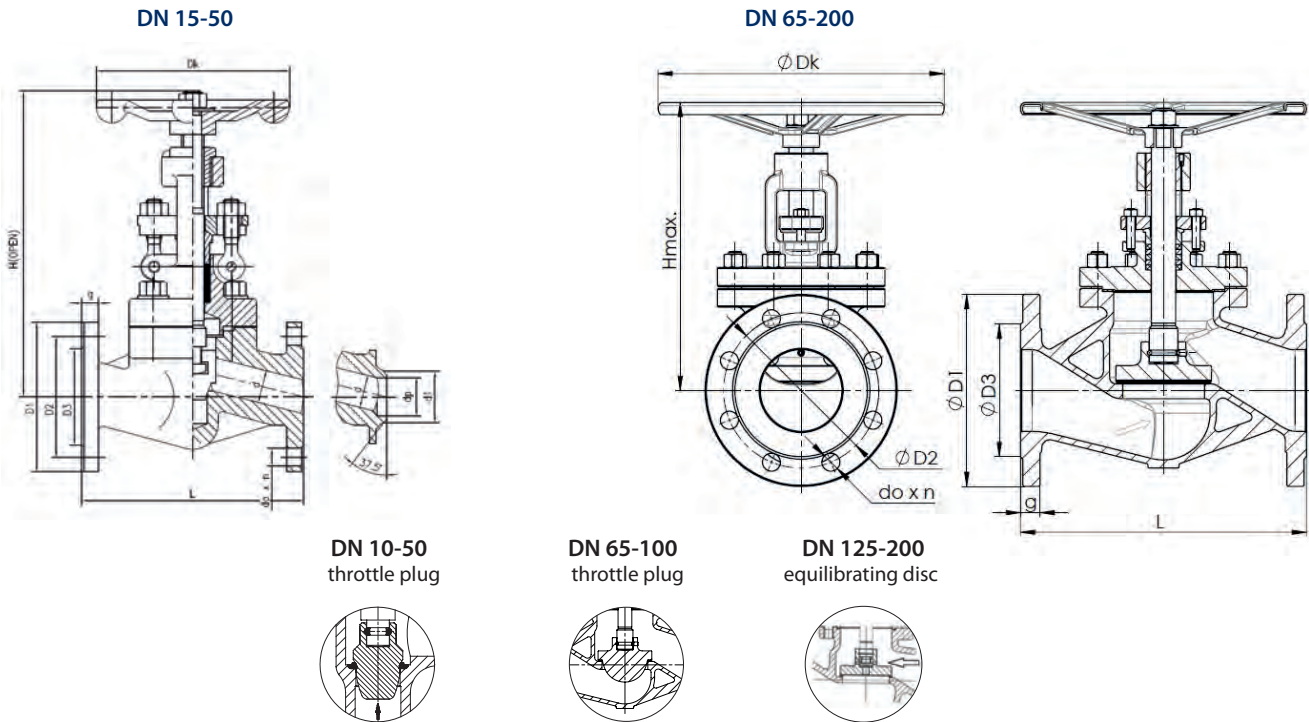

Material

Component	Tmax 450 °C	Tmax 450 °C	Tmax 550 °C**	Tmax 550 °C**
Body, bonnet	P250GH (1.0460)	GP240GH (1.0619)	X5CrNi18-10 (1.4301)	GX5CrNiMo19-11-2 (1.4408)
Seat	13Cr	13Cr	1.4301	1.4408
Disc DN 15-50	13Cr	-	SS304	-
Disc DN 65-200	-	1.0619	-	SS316
Disc ring	13Cr	13Cr	SS304	SS316
Stem	13Cr	-	SS304	SS316
Gasket	Graphite + Austenite			

** The temperatures listed above are designed for non-aggressive media. For aggressive media apply Tmax 250 °C.

PN	DN	D1	D2	D3	do x n	L	g	H _{max}	Dk	kg	Welded ends		
											d1	dp	kg
16 25 40	15	95	65	45	14 x 4	130	16	176	120	4,8	22	17	4
	20	105	75	58	14 x 4	150	18	206	140	5,8	28	22	5
	25	115	85	68	14 x 4	160	18	262	160	7,2	35	29	6,5
	32	140	100	78	18 x 4	180	18	210	160	8	44	37	7
	40	150	110	88	18 x 4	200	18	300	180	14,7	50	43	13,5
16	50	165	125	102	18 x 4	230	20	340	220	26	62	54,5	24,5
	65	185	145	122	8 x 18	290	18	315	250	21	77	69	19
	80	200	160	138	8 x 18	310	20	350	320	28	91	81	26
	100	220	180	158	8 x 18	350	20	398	350	44	117	104	41
	125	250	210	188	8 x 18	400	22	480	400	65	144	130,5	61
25	150	285	240	212	8 x 22	480	22	535	400	89	172	156,5	80
	200	340	295	268	12 x 22	600	24	675	500	171	223	204,5	160
	65	185	145	122	8 x 18	290	22	315	250	21	77	69	19
	80	200	160	138	8 x 18	310	24	350	320	28	91	81	26
	100	235	190	162	8 x 22	350	24	398	350	44	117	104	41
40	125	270	220	188	8 x 26	400	26	480	400	65	144	130,5	61
	150	300	250	218	8 x 26	480	28	535	400	89	172	156,5	80
	200	360	310	278	12 x 26	600	30	675	500	171	223	204,5	160
	65	185	145	122	18 x 8	290	22	315	250	21	77	69	19
	80	200	160	138	18 x 8	310	24	350	320	28	91	81	26
40	100	235	190	162	22 x 8	350	24	398	350	44	117	104	41
	125	270	220	188	26 x 8	400	26	480	400	65	144	130,5	61
	150	300	250	218	26 x 8	480	28	535	400	89	172	156,5	80
	200	375	320	285	30 x 12	600	34	675	500	171	223	204,5	160

PN 16-40 • DN 15-50 • Tmax 560 °C (450°C)

Connection: EN 1092-1, ISO 7005-1, GOST 12815-80 FLANGED ENDS
 EN 12627 WELDED ENDS

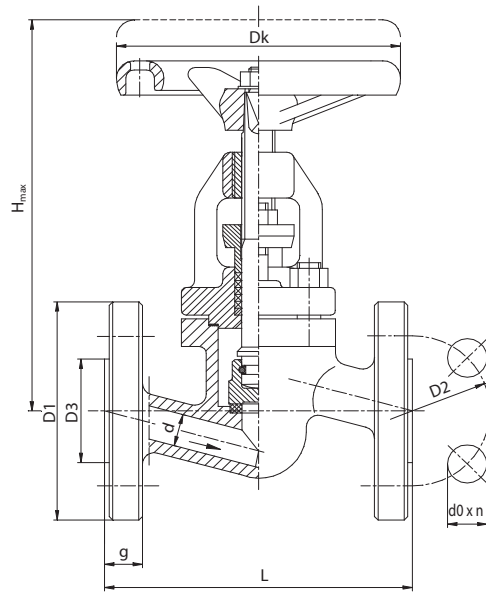

welded ends

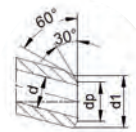

TYP V40
throttle plug

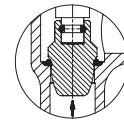

Material

Component	Tmax 450 °C	Tmax 530 °C	Tmax 560 °C	Tmax 550 °C **	Tmax 550 °C **
Body, bonnet DN 15-50	P250GH (1.0460)	16Mo3 (1.5415)	13CrMo4-5 (1.7335)	X6CrNiTi18-10 (1.4541)	X2CrNiMo17-12-2 (1.4404)
Seat	13Cr	Stellite	Stellite	SS316, Stellite	SS316, Stellite
Disc	13Cr	16Mo3 (1.5415)	13CrMo4-5 (1.7335)	1.4541	1.4404
Disc ring	13Cr	Stellite	Stellite	SS316, Stellite	SS316, Stellite
Stem	13Cr	13Cr	13Cr	1.4541	1.4404
Gasket	Graphite + Austenite				

** The temperatures listed above are designed for non-aggressive media. For aggressive media apply Tmax 250 °C.

PN	DN	d	D1	D2	D3	do x n	L	g	H _{max}	Dk	kg	d1	dp	kg
16	15	14	95	65	45	14 x 4	130	16	168	120	3,8	22	17	2,4
	20	19	105	75	58	14 x 4	150	18	168	120	4,5	28	22	2,5
	25	23	115	85	65	14 x 4	160	18	168	120	5	35	28,5	2,8
	32	30	140	100	78	18 x 4	180	18	210	160	9,5	44	37	6,2
	40	38	150	110	88	18 x 4	200	18	224	160	10,7	50	43	5,9
25	15	14	95	65	45	14 x 4	130	16	168	120	3,8	22	17	2,4
	20	19	105	75	58	14 x 4	150	18	168	120	4,5	28	22	2,5
	25	23	115	85	68	14 x 4	160	18	168	120	5	35	28,5	2,8
	32	30	140	100	78	18 x 4	180	18	168	160	9,5	44	37	6,2
	40	38	150	110	88	18 x 4	200	18	224	160	10,7	50	43	5,9
40	15	14	95	65	45	14 x 4	130	16	168	120	3,8	22	17	2,4
	20	19	105	75	58	14 x 4	150	18	168	120	4,5	28	22	2,5
	25	23	115	85	68	14 x 4	160	18	176	120	5	35	28,5	2,8
	32	30	140	100	78	18 x 4	180	18	210	160	9,5	44	37	6,2
	40	38	150	110	88	18 x 4	200	18	224	160	10,7	50	43	5,9
	50	45	165	125	102	18 x 4	230	20	239	160	12,8	62	54	8,1

* These dimensions of welded ends may vary acc. To the specifications of customer orders.