



Application

Gate valves are shut-off valves. It is used especially in power engineering, chemical industry as well as other industries depending on material selection.

Working medium

- water
- steam
- gas
- other fluids

Technical description

The body is a forging into which a flexible wedge is inserted through the yoke-type bonnet or through the pressure seal bonnet. The seating surfaces of the wedge are hard faced and proper seating of the wedge is provided for by precision-machined guides in the body. The seat rings are weld deposited in the body and hard faced as well. The bonnet and the stuffing box are sealed with special graphite gaskets and packing rings. The gate valves can be on request designed with pressure cavity released system against over pressurizing of body cavity. There is an option of drilling a hole on an input side of the disc, using diaphragm or safety valve or making a by-pass. Also upon request, the gate valve can be equipped with one to three bypass valves.

Connection to the piping

- **flanged ends** acc. to ASME B16.5
- **welded ends** acc. to ASME B16.25
- **socketed welding ends** acc. to ASME B16.11
- **threaded ends** acc. to ASME B1.20.1

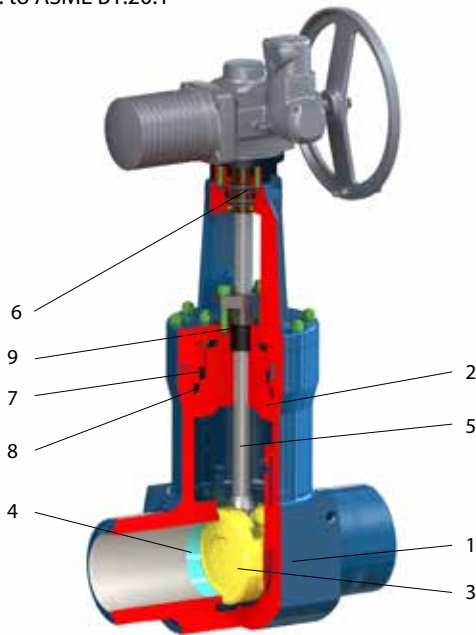

Operation

- manual (hand wheel)
 - electric actuator
 - pneumatic actuator
 - actuator located out of the valve
- Gate valves can be equipped with a locking device.

Testing

The gate valves are subjected to the following tests performed with water:

- shell strength test
- shell tightness test
- operability test
- other tests by agreement.

Installation

Gate valves may be installed in any position.

Position	Component
1	Body
2	Pressure seal bonnet
3	Wedge + overlay
4	Seat + overlay
5	Stem
6	Stem nut
7	Segmented ring
8	Gasket
9	Packing

Production range

Type	Class	NPS													
		1/2	3/4	1	1 1/2	2	2 1/2	3	4	6	8	10	12	14	16
S43.1	150									
	300									
	600									
	800									
	900									
	1500									
S43.5	900
	1500
	2500



NPS 1/2-2 • Class 150-1500 • Tmax • 538°C
 Body design: forged body, bolted bonnet

Connection: ASME B16.5 FLANGED ENDS
 ASME B16.11 SOCKED WELDING ENDS
 THREADED ENDS (on request)

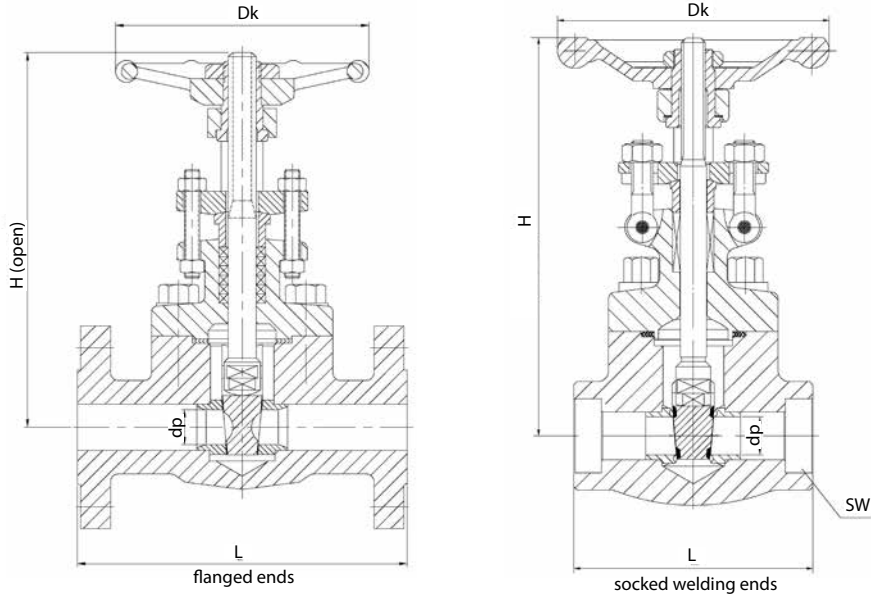

Material acc. to ASTM

Position	Component	Tmax 450°C	Tmax 538°C	Tmax 595°C
1	Body	A105	A182 F316	A182 F22
2	Bonnet	A105	A182 F316	A182 F22
3	Wedge + overlay*	A276 410T	A182 F316 + Stellite	A182 F22 + Stellite
4	Seat + overlay*	SS410 + Stellite	A182 F316 + Stellite	A182 F22 + Stellite
5	Stem	A182 F6	A182 F316	A182 F6
6	Bolt	A193 B7	A193 B8	A193 B7

*Other trims according to API 600

Class 150



NPS	Flanged ends					Socketed welding ends / SW				
	d	L	H	Dk	kg	d	L	H	Dk	kg
1/2	10,5	108	180	100	3,40	10,5	79	161	100	2,20
3/4	13	117	182	100	3,80	13,5	92	163	100	2,40
1	17	127	216	125	5,90	17	111	196	125	4,20
1 1/2	28	165	246	160	9,90	29	120	251	160	6,20
2	36	178	283	180	14,70	36,5	140	290	180	10,50

Class 300

NPS	Flanged ends					Socketed welding ends / SW				
	d	L	H	Dk	kg	d	L	H	Dk	kg
1/2	10,5	140	165	100	3,70	10,5	79	161	100	2,20
3/4	13	152	169	100	4,90	13,5	92	163	100	2,40
1	17	165	194	125	7,00	17	111	196	125	4,20
1 1/2	28	190	246	160	12,20	29	120	251	160	6,20
2	36	216	283	180	16,90	36,5	140	290	180	10,50



NPS ½-2 • Class 150-1500 • Tmax • 538°C
Body design: forged body, bolted bonnet

Connection:  ASME B16.5 FLANGED ENDS
 ASME B16.11 SOCKED WELDING ENDS
 THREADED ENDS (on request)

Class 600

NPS	Flanged ends					Socketed welding ends / SW				
	d	L	H	Dk	kg	d	L	H	Dk	kg
1/2	10,5	165	165	100	4,10	10,5	79	161	100	2,20
3/4	13	190	169	100	5,50	13,5	92	163	100	2,40
1	17	216	194	125	8,00	17	111	196	125	4,20
1 1/2	28	241	246	160	10,80	29	120	251	160	6,20
2	36	292	283	180	20,60	36,5	140	290	180	10,50

Class 800

NPS	Socketed welding ends / SW				
	d	L	H	Dk	kg
1/2	10,5	79	161	100	2,20
3/4	13,5	96	163	100	2,40
1	17	111	196	125	4,20
1 1/2	29	120	251	160	6,60
2	36,5	140	290	180	10,50

Class 900

NPS	Flanged ends					Socketed welding ends / SW				
	d	L	H	Dk	kg	d	L	H	Dk	kg
1/2	10,5	216	191	125	6,90	10,5	111	191	125	4,80
3/4	12,5	229	192	125	7,00	13,5	111	192	125	4,90
1	17	254	219	160	15,10	17,5	120	219	160	5,90
1 1/2	28	305	296	200	21,90	29	140	296	180	11,20
2	36	371	316	220	27,60	36,5	178	316	200	17,20

Class 1500

NPS	Flanged ends					Socketed welding ends / SW				
	d	L	H	Dk	kg	d	L	H	Dk	kg
1/2	10,5	216	191	125	7,00	10,5	111	191	125	4,90
3/4	12,5	229	192	125	7,10	13,5	111	192	125	5,00
1	17	254	219	160	15,30	17,5	120	219	160	6,00
1 1/2	28	305	296	200	22,10	29	140	296	180	11,40
2	36	371	316	220	27,80	36,5	178	316	200	17,50

*Class 2500 on request