

Application

Gate valves are shut-off valves. It is used especially in power engineering, chemical industry as well as other industries depending on material selection.

Working medium

- water
- steam
- gas
- other fluids

Technical description

The body is a forging into which a flexible wedge is inserted through the yoke-type bonnet or through the pressure seal bonnet. The seating surfaces of the wedge are hard faced and proper seating of the wedge is provided for by precision-machined guides in the body. The seat rings are weld deposited in the body and hard faced as well. The bonnet and the stuffing box are sealed with special graphite gaskets and packing rings. The gate valves can be on request designed with pressure cavity released system against over pressurizing of body cavity. There is an option of drilling a hole on an input side of the disc, using diaphragm or safety valve or making a by-pass. Also upon request, the gate valve can be equipped with one to three bypass valves.

Connection to the piping

- **flanged ends** acc. to EN 1092-1, ISO 7005-1, GOST 33259-2015
- **welded ends** acc. to EN 12627



Operation

- manual (hand wheel)
- electric actuator
- pneumatic actuator
- actuator located out of the valve

Gate valves can be equipped with a locking device.

Testing

The gate valves are subjected to the following tests performed with water:

- shell strength test
- shell tightness test
- seat tightness test and operability test according to EN 12266
- other tests by agreement.

Installation

The gate valves may be installed into the piping in vertical or horizontal position. In case of gate valves equipped with an electric actuator or a pneumatic actuator, must you follow instructions of the manufacturer of actuators.

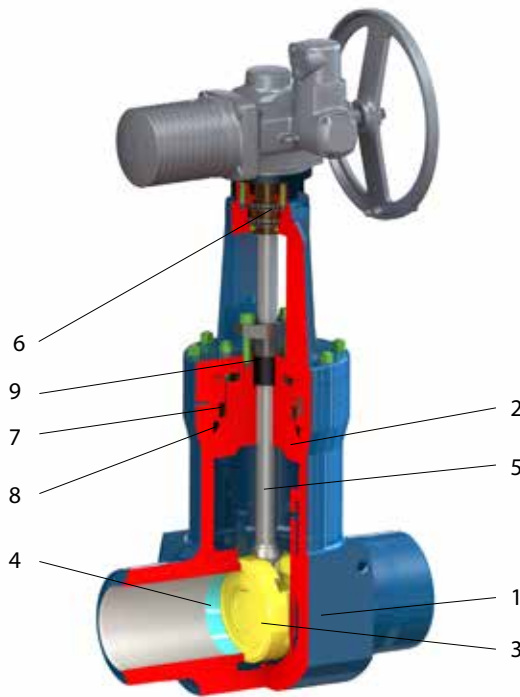

Position	Component
1	Body
2	Pressure seal bonnet
3	Wedge + overlay
4	Seat + overlay
5	Stem
6	Stem nut
7	Segmented ring
8	Gasket
9	Packing

Production range

Typ	PN	DN												
		50	65	80	100	125	150	200	250	300	350	400	500	600
S43.1	63
	100
S43.3	16
	25
	40
	63
S43.5	100
	160
	250
	320
	400



DN 50-350 • PN 63-100 • Tmax 600 °C (450 °C)
 Body design: forged body, bolted bonnet
 Gate valve can be supplied in cast design as well.
 Rising stem

Connection: EN 1092-1, ISO 7005-1, GOST 33259-2015 FLANGED ENDS
 EN 12627 WELDED ENDS

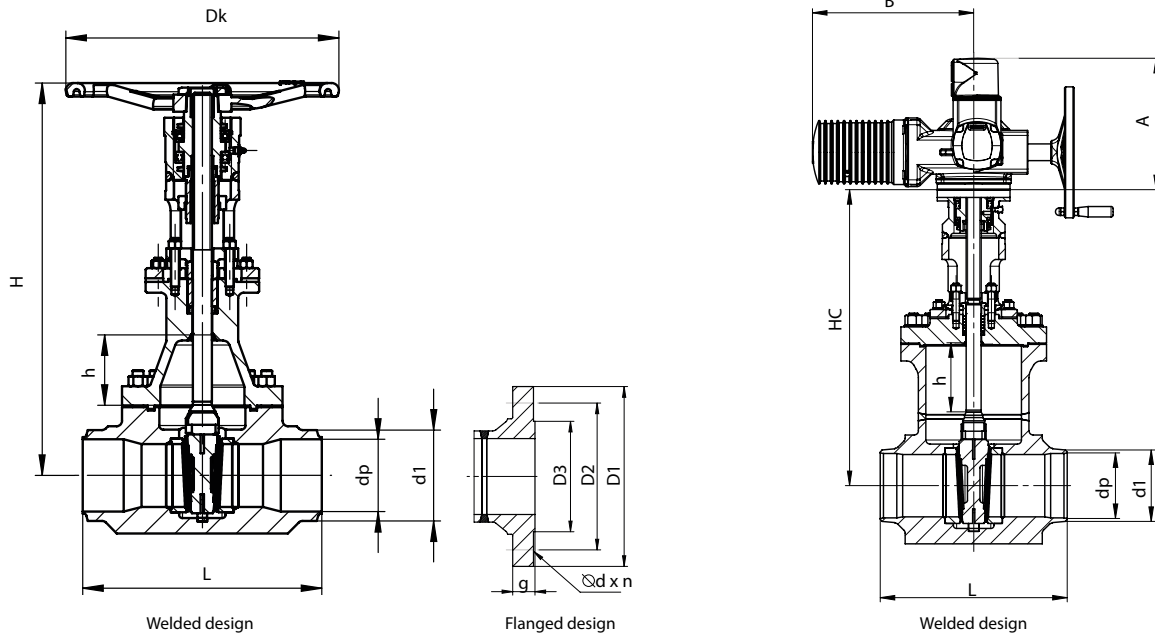

Material acc. to EN

Component	T _{max} 450 °C	T _{max} 530 °C	T _{max} 560 °C	T _{max} 570 °C	T _{max} 600 °C
Body, bonnet, wedge	P250GH (1.0460)	16Mo3 (1.5415)	13CrMo4-5 (1.7335)	14MoV6-3 (1.7715)	11CrMo9-10 (1.7383)
Stem	X39CrMo17-1 (1.4122)				
Seat + overlay	1.0460 + Stellite	1.5415 + Stellite	1.7335 + Stellite	1.7715 + Stellite	1.7383 + Stellite
Wedge + overlay	1.0460 + Stellite	1.5415 + Stellite	1.7335 + Stellite	1.7715 + Stellite	1.7383 + Stellite
Packing ring	Graphite				

PN 63-100

		Welded ends									
DN	d1	dp		L	H	HC	HC	h	Dk	kg PN 63	kg PN 100
		PN 63	PN 100								
50	62	54		250	463	430	430	61	400	28,2	32,2
65	77	69		290	624	420	420	77	400	40,9	45,9
80	91	81		310	545	520	520	92	500	48,7	49,7
100	117	104		350	590	530	530	115	500	70,6	81,6
125	144	130,5	127	400	700	640	640	140	500	133,9	135,9
150	172	156,5	154	450	760	700	700	160	700	215,1	228,1
200	223	204,5	199,5	550	920	850	85	225	700	260,0	360,0
250	278	255	248,5	650	1180	980	980	270	850	440,2	591,4
300	329	301	295,5	750	1540	1450	1450	325	800	604,5	864,0
350	362	330		850	1395	1500	1500	355	630	814,6	963,8

PN 63-100

Flanged ends														
DN	L	D3	PN 63							PN 100				
			D1		D2	$\varnothing d \times n$	g	kg	D1		D2	$\varnothing d \times n$	g	kg
			GOST	EN					GOST	EN				
50	250	102	175	180	135	22 x 4	26	39	195		145	26 x 4	30	43
65	290	122	200	205	160	22 x 8	26	56	220		170	26 x 8	34	61
80	310	138	210	215	170	22 x 8	28	62	230		180	26 x 8	36	63
100	350	162	250		200	26 x 8	30	97	265		210	30 x 8	40	108
125	400	188	295		240	30 x 8	34	164	310	315	250	33 x 8	40	166
150	450	218	340	345	280	33 x 12	36	265	350	355	290	33 x 12	44	278
200	550	285	405	415	345	36 x 12	42	335	430		360	36 x 12	52	437
250	650	345	470		400	36 x 16	46	498	500	505	430	39 x 12	60	692
300	750	410	530		460	36 x 16	52	677	585		500	42 x 16	68	1010
350	850	465	595	600	525	39 x 16	56	914	655		560	48 x 16	74	1158

Dimensions A and B depend on the particular actuator type.