

POTRUBÍ A PŘÍSLUŠENSTVÍ  
TUBE AND PIPE EQUIPMENT

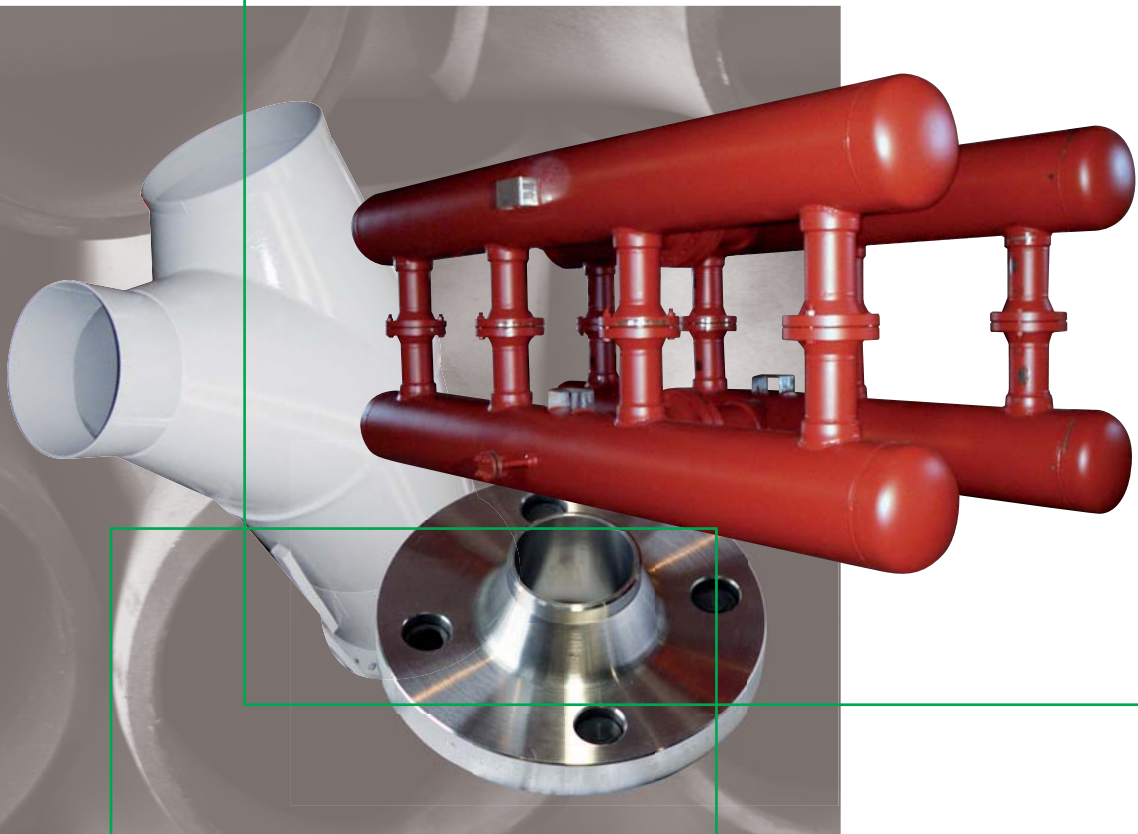

PRODUKTOVÝ KATALOG  
PRODUCT CATALOGUE

# GARANTUJEME KVALITU

WE GUARANTEE QUALITY



## MATERIÁLY | MATERIALS

- UHLÍKOVÁ OCEL | CARBON STEEL
- UHLÍKOVÁ OCEL PRO MINUSOVÉ TEPLoty  
LOW TEMPERATURE CARBON STEEL
- LEGOVANÁ OCEL | ALLOY STEEL
- NEREZOVÁ OCEL | STAINLESS STEEL
- SPECIÁLNÍ OCELI ( P91, P92, atd.)  
SPECIAL STEELS ( P91, P92, etc.)

## NORMY | STANDARDS

- ČSN, DIN, EN, ASME/ANSI, ATYP

## DOKUMENTACE | DOCUMENTATION

- ČSN EN 10204 - 3.1, 3.2,  
TRD, ADW, PED, atd./etc.

## REFERENCE | REFERENCES

Rok / Year	Název projektu / Name of the project	Místo realizace / Place	Stát / State	Zákazník / Customer
2003 - 2004	Výstavba a rekonstrukce závodu na výrobu plynu Construction and reconstruction of the gas production plant	Sosnogorsk	Rusko / Russia	ŠKODA JS a.s.
2004, 2007	Výstavba plynostanice LUKOIL Korobkovsky Construction of the gas station LUKOIL Korobkovsky	Kotovo	Rusko / Russia	ČKD PRAHA DIZ, a.s.
2005	Generální dodavatel opravy kotle TG33 v Teplárně Třebovice, Dalkia ČR General supplier for reconstruction of the boiler TG33, Heating plant Trebovice, Dalkia ČR	Ostrava	Česká republika / Czech Republic	ŠKODA POWER a.s.
2005	Výstavba krakovacích pecí Construction of the cracking furnace	Kirishi	Rusko / Russia	ABB Lummus Global s.r.o.
2005	Výstavba hydrogenační linky HL7 v BorsodChem MCHZ Construction of the hydrocracke unit HL7 in BorsodChem MCHZ	Ostrava	Česká republika / Czech Republic	Chemoprojekt, a.s.
2006 - 2007	Výstavba Teplárny Tábor Construction of the Heating plant Tabor	Tábor	Česká republika / Czech Republic	PROFITALL, spol. s r.o.
2007	Výstavba nové jednotky na výrobu čpavku Construction of the ammonia unit	Šaľa	Slovensko / Slovakia	Kovoprojekta Brno a.s.
2007	Výstavba kotle - vnější spojovací potrubí Construction of the boiler and external connecting pipeline	Bukurešť	Rumunsko / Romania	Modřanská potrubní, a.s.
2007	Výstavba Rafinerie Basra Construction of the Refinery Basra	Basra	Irák / Iraq	UNIS, a.s.
2007	Výstavba závodu na výrobu biodieselu (FAME) Construction of the biodiesel unit (FAME)	Leopoldov	Slovensko / Slovakia	Chemoprojekt, a.s.
2007	Výstavba stanice na výrobu pryskyřice, Setuza Construction of the resin unit, Setuza	Ústí nad Labem	Česká republika / Czech Republic	Kovoprojekta Brno a.s.
2007	Generální dodavatel potrubních celků pro elektrárnu Balloki 225 MW General supplier of the pipeline for the gas power station 225 MW	Balloki	Pákistán / Pakistan	ČKD EXPORT, a.s.
2007	Rekonstrukce krakovací jednotky Reconstruction of the hydrocracke conversion and capacity increasing	Litvínov	Česká republika / Czech Republic	CB&I Lummus s.r.o.
2007	Výstavba selektivní hydrogenační rafinace Construction of the hydrocracke unit	Kralupy nad Vltavou	Česká republika / Czech Republic	CB&I Lummus s.r.o.
2008	Generální dodavatel potrubních celků pro elektrárnu Muridke 234 MW General supplier of the pipeline for the gas power station 234 MW	Muridke	Pákistán / Pakistan	ČKD EXPORT, a.s.
2008	Výstavba jednotky pro destilaci benzenu Construction of the benzene rectification unit	Litvínov	Česká republika / Czech Republic	Intecha, spol. s r.o.
2008	Výstavba Elektrárny Dunafer Construction of the power station Dunafer	Alchevsk	Ukrajina / Ukraine	Austrian Enegy & Environment
2008	Úprava lihovaru Trmice Construction of the distillery Trmice	Trmice	Česká republika / Czech Republic	EUROMONT GROUP a.s.
2008	Výstavba kompresní plynové stanice, Narjan Mar Construction of the gas station, Narjan Mar	Usinsk	Rusko / Russia	ČKD PRAHA DIZ, a.s.
2008	Rekonstrukce kotle K13 v Elektrárně Třebovice Reconstruction of the boiler K13 in power station Trebovice	Ostrava	Česká republika / Czech Republic	PROFITALL, spol. s r.o.
2008	Komplexní obnova rafinerie v Baiji Complex reconstruction of the isomerization unit in Baiji refinery	Baiji	Irák / Iraq	Chemoprojekt, a.s.
2008	Výstavba parní turbíny Construction of the steam turbine	Kielce	Polsko / Poland	Ekol, spol. s r.o.

# CO MÁME SKLADEM - POTRUBÍ A PŘÍSLUŠENSTVÍ

IN STOCK - TUBE AND PIPE EQUIPMENT



## TYP | TYPE

### TRUBKY A ROURY | TUBES AND PIPES

- bezešvé, svařované aj. / seamless, welded etc.
- silnostěnné, izolované aj. / heavy wall thickness, insulated etc.

### PŘÍRUBY | FLANGES

- krkové, točivé, zaslepovací, závitové aj. / welding-neck, slip-on, blind, screwed etc...

### TVAROVKY | FITTINGS

- T kusy, oblouky, redukce, dna aj. / tee, elbow, reducers, caps etc.

### VÝKOVKY | FORGINS

- hrdla / weldolets, sockolets

### ŠROUBY, MATICE | FASTENERS, BOLTS-NUTS

### TĚSNĚNÍ | GASKETS

### ULOŽENÍ | SUPPORTS



**Komplexní obnova Elektrárny Tušimice, ČR**  
Dodávky trubek, svařenců a tvarovek  
Complex reconstruction of power plant Tušimice,  
Czech Republic  
Complex supply of pipes, weldment and fittings



**Skladové hospodářství**  
Warehouse



**Výstavba rafinerie INA Rijeka, Chorvatsko**  
Dodávka izolovaného potrubí  
Construction of hydrocrack unit INA Rijeka  
Refinery, Croatia  
Supply of insulated pipes



**Skladové hospodářství**  
Warehouse



**Generální dodavatel potrubních celků pro elektrárnu**  
Balloki 225 MW CCPP, Pákistán  
Dodávka silnostěnných trubek P91  
General supplier of the pipeline for the gas power  
station Balloki 225 MW CCPP, Pakistan  
Supply of heavy wall thickness pipes P91



**Skladové hospodářství**  
Warehouse

# CO VÁM ZAJISTÍME – PREFABRIKACI POTRUBÍ

WE CAN SUPPLY - PREFABRICATION OF THE PIPELINE

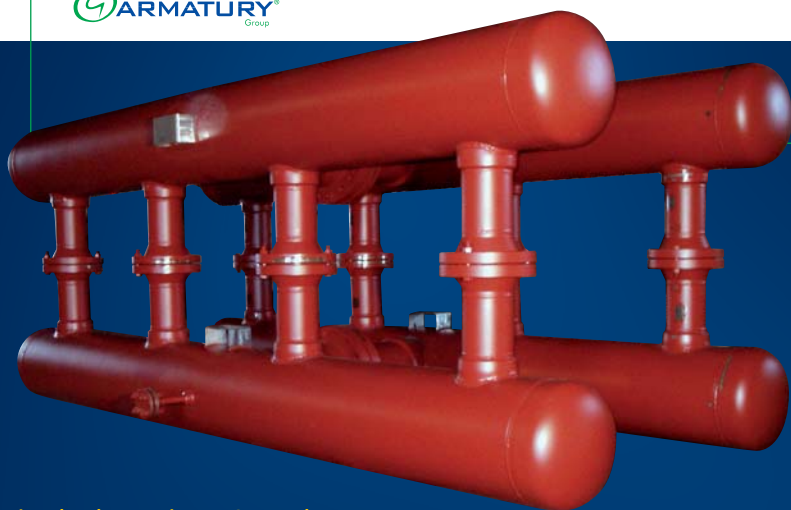

## TYP | TYPE

KOMORY | CHAMBERS

OHYBY | BENDS

ROZDĚLOVAČE | MANIFOLDS

SBĚRAČE | COLLECTORS

MEMBRÁNOVÉ STĚNY | MEMBRANE PANEL

TRUBKOVNICE | TUBE PLATE

OHŘÍVAČE VZDUCHU | AIR-HEATING APPARATUS

TLAKOVÉ NÁDOBY | PRESSURE VESSEL

Výstavba plynostanice LUKOIL, Rusko  
Vysokotlaké rozdělovače plynu 16" 300 lb  
Construction of gas station LUKOIL, Russia  
High pressure manifolds 16" 300 lb



Elektrárna ALCHEVSK, Ukrajina  
Dodávka prefabrikace potrubí  
Power plant ALCHEVSK, Ukraine  
Supply of the pipeline prefabrication



Výstavba teplárny Tábor, ČR  
Dodávka vysokotlaké komory  
Construction of heating plant Tabor,  
Czech Republic  
Supply of high pressure chamber



Výstavba teplárny Plzeň, ČR  
Dodávka bubnu - kotel K7  
Construction of heating plant Plzen,  
Czech Republic  
Supply of boiler's K7 cylinder



Rekonstrukce a výstavba plynostanice Sosnogorsk, Rusko / Dodávka tlakového sběrače a rozdělovače  
Reconstruction and construction of gas station Sosnogorsk, Russia  
Supply of pressure manifolds and collectors



Výstavba rafinerie Kirishi, Rusko  
Prefabrikace potrubí  
Reconstruction of hydrocrack unit Kirishi, Russia  
Prefabrication of pipeline



Výstavba teplárny Chomutov, ČR  
Dodávka membránové stěny  
Construction of heating plant Chomutov,  
Czech Republic  
Supply of membrane panels

# CO VÁM VYROBÍME – SVAŘENCE

WE CAN PRODUCE - WELDMENT



## TYP | TYPE

SÍTA | SCREENS  
FILTRY | STRAINERS  
ATYPICKÉ TRUBKY | ATYPICAL TUBES

TO VŠE VČETNĚ  
KONEČNÝCH  
POVRCHOVÝCH  
ÚPRAV | ALL ITEMS  
INCLUDING THE  
FINAL PAINTING

Výstavba vodní elektrárny Brodrene Dahl, Norsko  
Vstupní potrubí pro turbínu  
Construction of hydropower plant Brodrene Dahl, Norway  
Inlet pipe to turbine



Výstavba vodní elektrárny, Norsko  
Dodávka svařence „kalhoty“ DN 1000  
Construction of hydropower plant, Norway  
Supply of pig trap DN 1000



Výstavba plynostanice LUKOIL Korobkovsky, Rusko  
Dodávka T-kusů DN 800 do plynového potrubí  
Construction of gas station LUKOIL Korobkovsky, Russia  
Supply of Tee pieces DN 800 for gas pipeline



Rekonstrukce a výstavba plynostanice Sosnogorsk, Rusko / Dodávka filtrů se sítím 24" 600 lb  
Reconstruction and development of gas station Sosnogorsk, Russia / Supply of Strainers 24" 600 lb



Rekonstrukce ropného terminálu, Estonsko  
Dodávka ježkovacích komor DN 600  
Reconstruction of the oil terminal, Estonia  
Supply of pig trap DN 600



Výstavba kompresní stanice plynu Narjan Mar, Rusko  
Dodávka nerezového síta (konstrukce AG) a plynového potrubí  
Construction of compression gas station Narjan Mar, Russia / Supply of stainless steel screen (AG Design) and gas pipeline



Výstavba přečerpávací stanice Booster, Norsko  
Dodávka atypické trubky DN 1200  
Construction of pump station Booster, Norway  
Supply of atypical tube DN 1200

PIPE COMPARISON ACC. TO ASME 36.10

NPS	DN	O.D.mm	S5S	S10S	S10	S20	S30	STD	S40	S60	XS	S80	S100	S120	S140	S160	XXS	
1/8	6	10,30	-	1,24	1,24	-	1,45	1,73	1,73	-	2,41	2,41	-	-	-	-	-	
			-	0,28	0,28	-	0,32	0,37	0,37	-	0,47	0,47	-	-	-	-	-	-
1/4	8	13,70	-	1,65	1,65	-	1,85	2,24	2,24	-	3,02	3,02	-	-	-	-	-	
			-	0,51	0,49	-	0,54	0,63	0,63	-	0,80	0,80	-	-	-	-	-	-
3/8	10	17,10	-	1,65	1,65	-	1,85	2,31	2,31	-	3,20	3,20	-	-	-	-	-	
			-	0,64	0,63	-	0,70	0,84	0,84	-	1,10	1,10	-	-	-	-	-	-
1/2	15	21,30	1,65	2,11	2,11	-	2,41	2,77	2,77	-	3,73	3,73	-	-	-	4,78	7,47	
			0,82	1,01	1,00	-	1,12	1,27	1,27	-	1,62	1,62	-	-	-	-	1,95	2,55
3/4	20	26,70	1,65	2,11	2,11	-	-	2,87	2,87	-	3,91	3,91	-	-	-	-	5,56	7,82
			1,04	1,31	1,28	-	-	1,69	1,69	-	2,20	2,20	-	-	-	-	2,90	3,64
1	25	33,40	1,65	2,77	2,77	-	-	3,38	3,38	-	4,55	4,55	-	-	-	-	6,35	9,09
			1,33	2,13	2,09	-	-	2,50	2,50	-	3,24	3,24	-	-	-	-	-	-
1 1/4	32	42,20	1,65	2,77	2,77	-	-	3,56	3,56	-	4,85	4,85	-	-	-	-	6,35	9,70
			1,68	2,76	2,69	-	-	3,39	3,39	-	4,47	4,47	-	-	-	-	6,51	7,77
1 1/2	40	48,30	1,65	2,77	2,77	-	-	3,68	3,68	-	5,08	5,08	-	-	-	-	7,14	10,15
			1,95	3,17	3,11	-	-	4,05	4,05	-	5,41	5,41	-	-	-	-	7,25	9,56
2	50	60,30	1,65	2,77	2,77	-	3,18	3,91	3,91	-	5,54	5,54	-	-	-	-	8,74	11,07
			2,44	4,01	3,93	-	4,48	5,44	5,44	-	7,48	7,48	-	-	-	-	11,11	13,44
2 1/2	65	73,00	2,11	3,05	3,05	-	4,78	5,16	5,16	-	7,01	7,01	-	-	-	-	9,53	14,02
			3,77	5,36	5,26	-	8,04	8,63	8,63	-	11,41	11,41	-	-	-	-	14,92	20,39
3	80	88,90	2,11	3,05	3,05	-	4,78	5,49	5,49	-	7,62	7,62	-	-	-	-	11,13	15,24
			4,60	6,59	6,46	-	9,92	11,29	11,29	-	15,27	15,27	-	-	-	-	21,35	27,68
3 1/2	90	101,60	2,11	3,05	3,05	-	4,78	5,74	5,74	-	8,08	8,08	-	-	-	-	-	-
			5,29	7,55	7,41	-	11,41	13,57	13,57	-	18,63	18,63	-	-	-	-	-	-
4	100	114,30	2,11	3,05	3,05	-	4,78	6,02	6,02	-	8,56	8,56	-	11,13	-	13,49	17,12	
			5,96	8,52	8,37	-	12,91	16,07	16,07	-	22,32	22,32	-	28,32	-	33,54	41,03	
5	125	141,30	2,77	3,40	3,40	-	-	6,55	6,55	-	9,53	9,53	-	12,70	-	15,88	19,05	
			9,67	11,82	11,56	-	-	21,77	21,77	-	30,97	30,97	-	40,28	-	49,11	57,43	
6	150	168,30	2,77	3,40	3,40	-	-	7,11	7,11	-	10,97	10,97	-	14,27	-	18,26	21,95	
			11,55	14,13	13,83	-	-	28,26	28,26	-	42,56	42,56	-	54,20	-	67,56	79,22	
8	200	219,10	2,77	3,76	3,76	6,35	7,04	8,18	8,18	10,31	12,70	12,70	15,09	18,26	20,62	23,01	22,23	
			15,09	20,37	19,97	33,31	36,81	42,55	42,55	53,08	64,64	64,64	75,92	90,44	100,92	111,27	107,92	
10	250	273,00	3,40	4,19	4,19	6,35	7,80	9,27	9,27	12,70	12,70	15,09	18,26	21,44	25,40	28,58	25,40	
			23,08	28,34	27,78	41,77	51,03	60,31	60,31	81,55	81,55	96,01	-	-	-	-	-	
12	300	323,80	3,96	4,57	4,57	6,35	8,38	9,53	10,31	14,27	12,70	17,48	21,44	25,40	28,58	33,32	25,40	
			31,89	36,73	35,98	49,73	65,20	73,88	79,73	108,96	97,46	132,08	159,91	186,97	208,14	238,76	186,97	
14	350	355,60	3,96	4,78	6,35	7,92	9,53	9,53	11,13	15,09	12,70	19,05	23,83	27,79	31,75	35,71	-	
			35,06	42,14	54,69	54,69	67,90	81,33	94,55	126,71	107,39	158,10	194,96	224,65	253,56	281,70	-	
16	400	406,40	4,19	4,78	6,35	7,92	9,53	9,53	12,70	16,66	12,70	21,44	26,19	30,96	36,53	40,49	-	
			42,41	48,26	62,64	77,83	93,27	93,27	123,30	160,12	123,30	203,56	245,56	286,64	333,19	365,35	-	
18	450	457,00	4,19	4,78	6,35	7,92	11,13	9,53	14,27	19,05	12,70	23,83	29,36	34,93	39,67	45,24	-	
			47,77	54,36	70,57	87,71	122,38	105,16	155,80	205,74	139,15	154,55	309,62	363,56	408,26	459,37	-	
20	500	508,00	4,78	5,54	6,35	9,53	12,70	9,53	15,09	20,62	12,70	26,19	32,54	38,10	44,45	50,01	-	
			60,46	70,00	78,55	117,15	155,12	117,15	183,42	147,83	155,12	311,17	381,53	441,49	508,11	564,81	-	
22	-	559,00	4,78	5,54	6,35	9,53	12,70	9,53	-	22,23	12,70	28,58	34,93	41,28	47,63	53,98	-	
			66,57	77,06	86,54	129,13	171,09	129,13	-	294,25	171,09	373,83	451,42	527,02	600,63	672,26	-	
24	600	610,00	5,54	6,35	6,35	9,53	14,27	9,53	17,48	24,61	12,70	30,96	38,89	46,02	52,37	59,54	-	
			84,16	96,37	94,53	141,12	209,64	141,12	255,41	355,26	187,06	442,08	547,71	640,03	720,15	808,22	-	
26	-	660,00	-	-	7,92	12,70	-	9,53	-	-	12,70	-	-	-	-	-	-	
			-	-	127,36	202,72	-	152,87	-	-	202,72	-	-	-	-	-	-	-
28	700	711,00	-	-	7,92	12,70	15,88	9,53	-	-	12,70	-	-	-	-	-	-	
			-	-	137,32	218,69	271,21	164,85	-	-	218,69	-	-	-	-	-	-	-
30	-	762,00	6,35	7,92	7,92	12,70	15,88	9,53	-	-	12,70	-	-	-	-	-	-	
			120,72	150,36	147,28	234,67	292,18	176,84	-	-	234,67	-	-	-	-	-	-	-
32	800	813,00	-	-	7,92	12,70	15,88	9,53	17,48	-	12,70	-	-	-	-	-	-	
			-	-	157,24	250,64	312,15	188,82	342,91	-	250,64	-	-	-	-	-	-	-
34	-	864,00	-	-	7,92	12,70	15,88	9,53	17,48	-	12,70	-	-	-	-	-	-	
			-	-	167,20	266,61	332,12	200,31	364,90	-	266,61	-	-	-	-	-	-	-
36	900	914,00	-	-	7,92	12,70	15,88	9,53	19,05	-	12,70	-	-	-	-	-	-	
			-	-	176,96	282,27	351,70	212,56	420,42	-	282,27	-	-	-	-	-	-	-
38	-	965,00	-	-	-	-	-	9,53	-	-	12,70	-	-	-	-	-	-	
			-	-	-	-	-	224,54	-	-	298,24	-	-	-	-	-	-	-
40	1000	1016,00	-	-	-	-	-	9,53	-	-	12,70	-	-	-	-	-	-	
			-	-	-	-	-	236,53	-	-	314,22	-	-	-	-	-	-	-
42	-	1067,00	-	-	-	-	-	9,53	-	-	12,70	-	-	-	-	-	-	
			-	-	-	-	-	248,52	-	-	330,19	-	-	-	-	-	-	-
44	1100	1118,00	-	-	-	-	-	9,53	-	-	12,70	-	-	-	-	-	-	
			-	-	-	-	-	260,50	-	-	346,16	-	-	-	-	-	-	-
46	-	1168,00	-	-	-	-	-	9,53	-	-	12,70	-	-	-	-	-	-	
			-	-	-	-	-	272,25	-	-	351,82	-	-	-	-	-	-	-
48	1200	1219,00	-	-	-	-	-	9,53	-	-	12,70	-	-	-	-	-	-	
			-	-	-	-	-	284,24	-	-	377,79	-	-	-	-	-	-	

## MATERIALS COMPARISON

MATERIÁL / NORMA MATERIAL / STANDARD	POTRUBÍ / PIPES				PŘÍRUBY / FLANGES				TVAROVKY / FITTINGS			
	ASTM	DIN	ČÍSLO OCELI / STEEL NUMBER	EN STANDARD	ASTM	DIN	ČÍSLO OCELI / STEEL NUMBER	EN STANDARD	ASTM	DIN	ČÍSLO OCELI / STEEL NUMBER	EN STANDARD
UHLÍKOVÁ OCEL / CARBON STEEL	A106-A	St 35.8	1.0305	P235G1TH					A234-WPA	St 35.8	1.0305	P235G1TH
	A106-B	St 45.8	1.0405	P265G1TH	A105	C21	1.0432		A234-WPB	St 45.8	1.0405	P265G1TH
NEREZOVÁ OCEL / STAINLESS STEEL	A312-TP304	X5CrNi18 10	1.4301	X5CrNi18-10	A182-F304	X5CrNi18 10	1.4301	X5CrNi18-10	A403-WP304	X5CrNi18 10	1.4301	X5CrNi18-10
	A312-TP304H	X6CrNi18 11	1.4948	X6CrNi18-10	A182-F304H	X6CrNi18 11	1.4948	X6CrNi18-10	A403-WP304H	X6CrNi18 11	1.4948	X6CrNi18-10
	AS12- TP304L	X2CrNi19 11	1.4306	X2CrNi19-11	A182-F304L	X2CrNi19 11	1.4306	X2CrNi19-11	A403-WP304L	X2CrNi19 11	1.4306	X2CrNi19-11
	A312- TP309 S	X7CrNi23 14	1.4833	X7CrNi23-13	A182-F309 S	X7CrNi23 14	1.4833	X7CrNi23-13	A403-WP309 S	X7CrNi23 14	1.4833	X7CrNi23-13
	A312-TP316	X5CrNiMo17 12.2	1.4401	X5CrNiMo17-12-2	A182-F316	X5CrNiMo17 12.2	1.4401	X5CrNiMo17-12-2	A403-WP316	X5CrNiMo17 12.2	1.4401	X5CrNiMo17-12-2
	A312-TP316H	X6CrNiMo17 13.2	1.4919	X6CrNiMo17-12-2	A182-F316H	X6CrNiMo17 13.2	1.4919	X6CrNiMo17-12-2	A403-WP316H	X6CrNiMo17 13.2	1.4919	X6CrNiMo17-12-2
	A312-TP316L	X2CrNiMo17 13.2	1.4404	X2CrNiMo17-12-2	A182-F316L	X2CrNiMo17 13.2	1.4404	X2CrNiMo17-12-2	A403-WP316L	X2CrNiMo17 13.2	1.4404	X2CrNiMo17-12-2
	A312-TP316Ti	XCrNiMoTi17 12.2	1.4571	XCrNiMoTi17-12-2	A182-F316Ti	XCrNiMoTi17 12.2	1.4571	XCrNiMoTi17-12-2	A403-WP316Ti	XCrNiMoTi17 12.2	1.4571	XCrNiMoTi17-12-2
	A312-TP317L	X2CrNiMo18-16-4	1.4438	X2CrNiMo18 15 4	A182-F317i	X2CrNiMo18-16-4	1.4438	X2CrNiMo18 15 4	A403-WP317L	X2CrNiMo18-16-4	1.4438	X2CrNiMo18 15 4
	A312-TP321	X6CrNiTi18-10	1.4541	X6CrNiTi18-10	A182-F321	X6CrNiTi18-10	1.4541	X6CrNiTi18-10	A403-WP321	X6CrNiTi18-10	1.4541	X6CrNiTi18-10
	A312-TP321H	X12CrNiTi18-9	1.4878	X12CrNiTi18-9	A182-F321H	X12CrNiTi18-9	1.4878	X12CrNiTi18-9	A403-WP321H	X12CrNiTi18-9	1.4878	X12CrNiTi18-9
	A312-TP347	X6CrNiNb18-10	1.4550	X6CrNiNb18-10	A182-F347	X6CrNiNb18-10	1.4550	X6CrNiNb18-10	A403-WP347	X6CrNiNb18-10	1.4550	X6CrNiNb18-10
	A312-TP347H	X6CrNiNb18-10	1.4550	X6CrNiNb18-10	A182-F347H	X6CrNiNb18-10	1.4550	X6CrNiNb18-10	A403-WP347H	X6CrNiNb18-10	1.4550	X6CrNiNb18-10
	N08926	X1NiCrMoCuN25-20-7	1.4529		A182-F316LN	X1NiCrMoCuN25-20-7	1.4529		N08926	X1NiCrMoCuN25-20-7	1.4529	
	N08904	X1NiCrMoCuN25-20-5	1.4539	904L	A182-F904L	X1NiCrMoCuN25-20-5	1.4539	904L	N08904	X1NiCrMoCuN25-20-5	1.4539	904L
	S31803	X2CrNiMoN22 5 3	1.4462	DUPLEX	A182-F51	X2CrNiMoN22 5 3	1.4462	DUPLEX	S31803	X2CrNiMoN22 5 3	1.4462	DUPLEX
S32750	X2CrNiMoWN25 7 4	1.4410	SUPER DUPLEX	A182-F53	X2CrNiMoWN25 7 4	1.4410	SUPER DUPLEX	S32750	X2CrNiMoWN25 7 4	1.4410	SUPER DUPLEX	
OCEL PRO NÍZKÉ TEPLOTY / LOW TEMPERATURE STEEL	A333-6	TTS135N/V	1.0356		A350-LF2	TStE355	1.0566	P355NL1	A420-WPL6	TTS135N/V	1.0356	
OCEL PRO VYSOKÉ TEPLOTY / HIGH TEMPERATURE STEEL	A335-P1	15Mo3	1.5415	16Mo3	A182-F1	15Mo3	1.5415	16Mo3	A234-WP1	15Mo3	1.5415	16Mo3
	A335-P5	12CrMo19-5	1.7362		A182-F5	12CrMo19-5	1.7362		A234-WP5	12CrMo19-5	1.7362	
	A335-P7	X12CrMo7	1.7368		A182-F7	X12CrMo7	1.7368		A234-WP7	X12CrMo7	1.7368	
	A335-P9	X12CrMo9-1	1.7386		A182-F9	X12CrMo9-1	1.7386		A234-WP9	X12CrMo9-1	1.7386	
	A335-P11				A182-F11				A234-WP11			
	A335-P12	13CrMo44	1.7335	13CrMo4-5	A182-F12	13CrMo44	1.7335	13CrMo4-5	A234-WP12	13CrMo44	1.7335	13CrMo4-5
	A335-P22	10CrMo9-10	1.7380	10CrMo9-10	A182-F22	10CrMo9-10	1.7380	10CrMo9-10	A234-WP22	10CrMo9-10	1.7380	10CrMo9-10
	A335-P91	X10CrMoVNb9-1	1.4903	X10CrMoVNb9-1	A182-F91	X10CrMoVNb9-1	1.4903	X10CrMoVNb9-1	A234-WP91	X10CrMoVNb9-1	1.4903	X10CrMoVNb9-1
VYSOKO- PEVNOSTNÍ OCEL / HIGH YIELD STEEL	API5L-A	StE 210.7	1.0307									
	API5L-B	StE 240.7	1.0457	L245NB								
	API5L-X42	StE 290.7	1.0484	L290NB	A694-F42	StE285	1.0486	P275N	A860-WPHY42	StE 290.7	1.0484	L290NB
	API5L-X46	StE 320.7	1.0409		A694-F46				A860-WPHY46	StE 320.7	1.0409	
	API5L-X52	StE 360.7	1.0582	L360NB	A694-F52	StE355	1.0562	P355N	A860-WPHY52	StE 360.7	1.0582	L360NB
	API5L-X56	StE 385.7	1.8970		A694-F56					StE 385.7	1.8970	
	API5L-X60	StE 415.7	1.8972	L415NB	A694-F60				A860-WPHY60	StE 415.7	1.8972	L415NB
	API5L-X65	StE 445.7TM	1.8975	L450MB	A694-F65	StE460	1.8905	P460N	A860-WPHYX65	StE 445.7TM	1.8975	L450MB
	API5L-X70	StE 480.7TM	1.8977	L485MB	A694-F70	StE500	1.8907		A860-WPHYX70	StE 480.7TM	1.8977	L485MB

Certifikát systému QMS dle  
DIN EN ISO 9001:2000  
QMS Certificate acc. to DIN EN  
ISO 9001:2000

Evropský certifikát jakosti  
pro svařování dle EN 729  
European quality Certificate  
for welding acc. to EN 729

Certifikát environmentálního  
systému podle normy DIN EN  
ISO 14001:2004  
EMS Certificate acc. to DIN EN  
ISO 14001:2004

Certifikát na tlaková zařízení  
pro potrubí a příslušenství dle  
PED 97/23/EC  
Pressure equipment for tube and  
pipe accessories Certificate acc.  
PED 97/23/EC



## KONTAKTNÍ ADRESY CONTACT ADDRESSES

### Česká republika Czech Republic

ARMATURY Group a.s.

**Provozovna a vedení společnosti**  
Production plant and Headquarters  
Hlučinská 41, 747 22 Dolní Benešov  
tel.: +420/553 680 111  
fax: +420/553 680 333  
email: dolni.benesov@agroup.cz

**Provozovna a sídlo společnosti**  
Production plant and Registered office  
Bolatická 39, 747 21 Kravaře  
tel.: +420/553 680 111  
fax: +420/553 680 333  
email: kravare@agroup.cz

**Provozovny / Sales offices**  
Lipnická 157, 753 61 Hranice IV - Drahotuše  
tel.: +420/581 658 111  
fax: +420/581 658 128  
email: hranice@agroup.cz

Špitálské náměstí 9, 400 01 Ústí nad Labem  
tel.: +420/475 211 908  
fax: +420/475 211 843  
email: usti@agroup.cz

### Slovensko Slovakia

ARMATÚRY GROUP, s.r.o.

**Provozovna a sídlo společnosti**  
Registered office  
Jánošíkova 264, 010 01 Žilina  
tel.: +421/41/707 77 77  
fax: +421/41/707 77 70  
email: zilina@armaturygroup.sk

**Provozovny / Sales offices**  
Južná trieda č. 74, 040 01 Košice  
tel.: +421/55/ 677 18 77  
fax: +421/55/ 677 18 78  
email: kosice@armaturygroup.sk

Murgašova 27, 927 00 Šaľa  
tel.: +421/31/770 00 67  
fax: +421/31/770 00 69  
email: sala@armaturygroup.sk

### Rusko Russia

АО „АРМАТУРЫ Групп“

3 Тверская-Ямская д.31/35  
125047 Москва, Россия  
тел./факс:tel./fax: +7/495 956 3335  
ел. почта/e-mail: ag-moscow@col.ru

[www.armaturygroup.cz](http://www.armaturygroup.cz)